

INSTRUCTIONS FOR: DIESEL INJECTION LEAK BACK MASTER SET BOSCH/DELPHI/DENSO



IMPORTANT: PLEASE READ THESE INSTRUCTIONS CAREFULLY. NOTE THE SAFE OPERATIONAL REQUIREMENTS, WARNINGS AND CAUTIONS. USE THE PRODUCT CORRECTLY AND WITH CARE FOR THE PURPOSE FOR WHICH IT IS INTENDED. FAILURE TO DO SO MAY CAUSE DAMAGE AND/OR PERSONAL INJURY AND WILL INVALIDATE THE WARRANTY. PLEASE KEEP INSTRUCTIONS SAFE FOR FUTURE USE.

1. SAFETY INSTRUCTIONS

- WARNING!** Ensure all Health and Safety, local authority, and general workshop practice regulations are strictly adhered to when using product.
- ✓ Maintain tools in a good clean condition for the best and safest performance. **DO NOT** use test kit if damaged.
- ✓ Wear approved eye protection. A full range of personal safety equipment is available from your dealer.
- ✓ Wear suitable clothing to avoid snagging. Do not wear jewellery and tie back long hair.
- WARNING!** Select neutral or 'park' if automatic transmission.
- ✓ Use proper ventilation and avoid breathing in exhaust fumes.
- ✓ Keep a fire extinguisher to hand.
- ✓ Protect your hands from burns as the engine may be hot after the test.
- ✓ Account for all tools and parts being used and do not leave them in, or on the engine after use.
- ✓ Ensure that any collected diesel is disposed of correctly in accordance with local authority guidelines.

IMPORTANT: Always refer to the vehicle manufacturer's service instructions, or proprietary manual to establish the current procedure and data. These instructions for use are provided as a guide only.



2. INTRODUCTION

Designed to measure return fuel flow on diesel vehicles up to 6 cylinders fitted with common rail injection system. Identifies, worn, blocked or inoperative injectors quickly and easily. Contains measurement tubes for short term tests and measurement bottles for long term, more accurate evaluation. Master kit includes range of adaptors to suit Bosch, Delphi & Denso injectors for comprehensive coverage of common rail diesel vehicles.

3. OPERATION

- 3.1 Most modern diesel vehicles are fitted with a sound deadening cowling over the top of the engine, remove this cowling to gain access to the injectors.
- 3.2 Direct Connection Tubes (Bosch connectors only fig.1). These tubes are ideal for a vehicle, which will not start and provide a very quick assessment.
 - 3.2.1 The return pipes are retained by wire clips, remove the clips and store in a safe place and gently ease out each of the return pipes from the injectors (fig.3). Take care not to break the connectors as they can be brittle.
 - 3.2.2 Plug the ends of the return pipes to avoid spillage.
 - 3.2.3 Connect the tubes into each injector (fig.4), the wire clips are not required as the return system is low pressure.
 - 3.2.4 Crank over the engine until the tubes are at least 50% full. Take care, that should the engine start the tubes will fill up very quickly.
 - 3.2.5 Check the levels in each injector. The levels should be less than 10% overall variation, any injector which has a back leakage problem will have more diesel in the tube.
 - 3.2.6 Remove the tubes from the injectors taking care not to spill any diesel, place a finger over the end of the tube to hold the liquid in the tube and then empty in to a suitable container.
 - 3.2.7 Refit the return pipes to the injectors and secure with the clips.
- 3.3 Flexible Tube, Adaptors and Bottles (fig.2). These will provide a more accurate reading as the engine will be running for longer.
 - 3.3.1 Remove the return pipes. Refer to the appropriate vehicle workshop manual.
 - 3.3.2 Connect the appropriate, Bosch, Delphi or Denso adaptors to the flexible tubes.
 - 3.3.3 Connect the flexible tubes into each injector and hang the bottle rack in a suitable position.
 - 3.3.4 Start or crank over the engine, run until the one of the bottles is approximately 75% full and stop the engine.
 - 3.3.5 Check the levels in each bottle any injectors with more than 10% more diesel in the bottle, may have a back leakage problem.
 - 3.3.6 Remove each tube from the injectors, taking care not to spill any diesel, if possible lower the bottle rack to a level below that of the injectors or raise the flexible tube, so that the fluid in the tubes drain into the bottles.
 - 3.3.7 Refit the return pipes to the injectors as per vehicle workshop manual.

NOTE: This system is designed to give a quick assessment of the return flow of the injectors, it is unable to determine all the factors which may affect the operation of the vehicle.

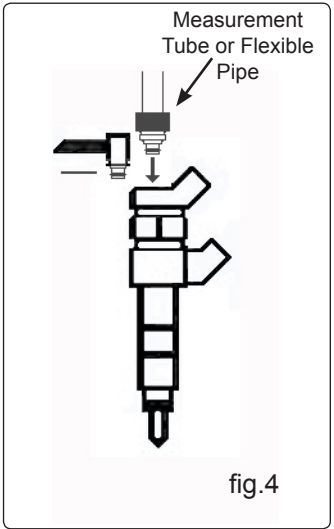
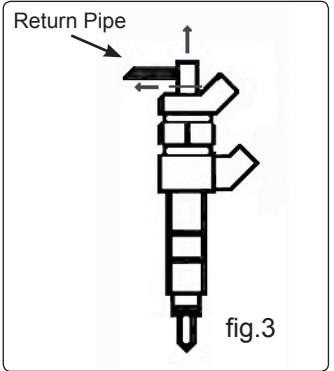
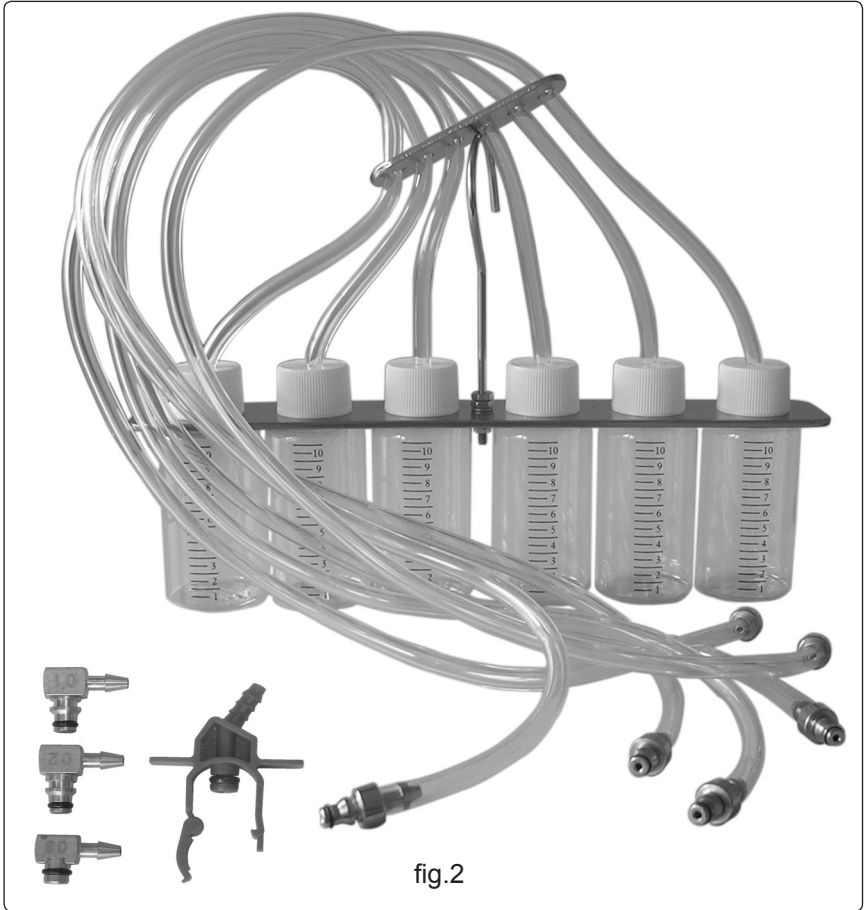

4. PARTS

Part No	Description
01	Bottle / Tube / Adaptor Assembly
02	Fluid Measure (Set of 6)
01	Denso Adaptor Set "1" (Set of 6)
02	Denso Adaptor Set "2" (Set of 6)
03	Denso Adaptor Set "3" (Set of 6)
04	Delphi Adaptor Set "4" (Set of 6)